

Worm Gear DC Motors 25W - 500W General catalogue

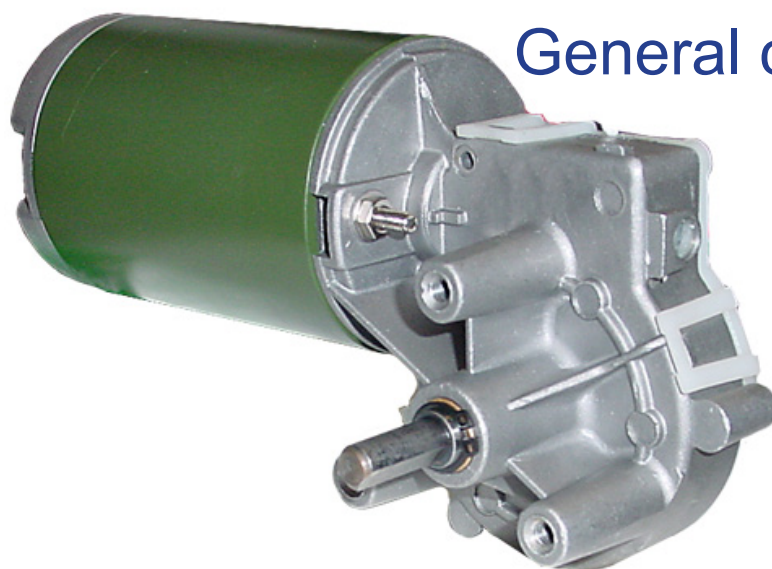

TABLE OF CONTENTS

	70-100mm	100-120mm	120-150mm	≥155
Ø43	WD4383 P.4			
Ø60	WD6093 P.5			
Ø63		WD63118 P.6		
Ø65		WD65111 P.7 WD65114 P.8		
Ø70		WD70107 P.9		
Ø80	WD8080 P.10 WD8089 P.11		WD80135 P.12 WD80136 P.13 WD80141 P.14	WD80155 P.15 WD80175 P.16
Ø89				WD89152 P.17
Ø123				WD123224 P.18

ENCODER OR BRAKE OPTIONS

This line of our motors and gear motors are also available with optical OE or magnetic encoder ME or electric brake B. Please check our price list and part numbers for the availability of combinations.

ENCODER DATA				
	MAGNETIC		OPTICAL	
Pulses per revolution PPR two channels together	24		1000	
Counts per revolution CPR two channels together	48		2000	
Phase shift	90 degrees		90 degrees	
VCC	+5 VDC	Orange lead	+5 VDC	Pin 1
GND	0 VDC	Green lead	0 VDC	Pin 5 Pin 8
Signal A		Blue lead		A- Pin 6
Signal B		Yellow lead		B- Pin 7
Current	< 80 mA			
Index	-		Z+ Pin 4	
Output wave	Line driver			
Frequency response	25 KHz max.			
Connector	Flying wire		DB9 female	
Weight	< 100 g			
Wire length	400mm		110mm	

ENCODER



OPTICAL OR MAGNETIC

BRAKE



BRAKE DATA	
Voltage	24VDC
Power	16W
Impedance	35Ω ±5%
Insulating Level	F
Dynamic Friction	35 KGF-cm
Static Friction	40 KGF-cm
Insulating Impedance	500 VDC / 50 MΩ
Insulating Withstanding Pressure	1500 VAC / 1mA / 1SEC
Releasing Time	40 msec
Attracting Time	140 msec
Operating Voltage	12V
Releasing Voltage	5V
Gap	0.12~0.15 mm
Weight	0.7 kg

ENCODER APPEARANCE SIZE

MAGNETIC AND OPTICAL

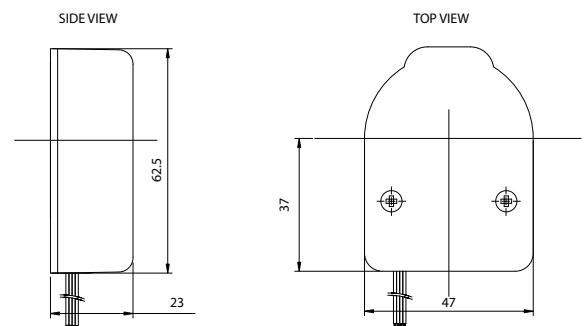

BRAKE SPECIFICATIONS

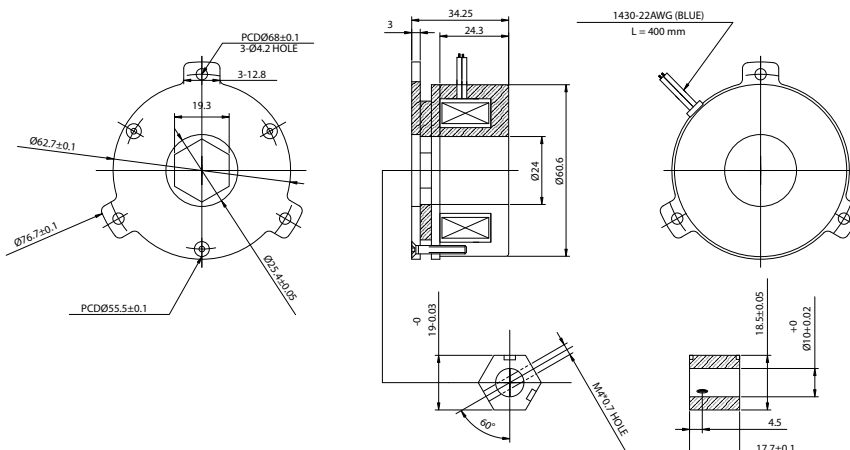

WLD4383 WORM GEAR DC MOTOR

Brush dc motors with robust design, plastic gears and closed motor body. Motor shafts are supported by ball bearings. Configurations may include gearbox, encoder and brake depending on motor model. Please check the part description for proper selections of combination. Customizations are welcome.

MODEL NO. DESIGNATIONS

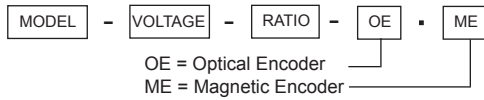

Example: WLDxxxx-12-60-OE

MOTOR FEATURES

- Robust design, closed motor body
- Ball bearings
- Gearbox combinations, plastic gears
- Encoder options
- Brake options
- Customizations are welcome

TRANSMOTEC SWEDEN AB

WLD4383



ENCODER VERSION AVAILABLE



SEE SEPARATE DATA SHEET

WORM GEAR DATA 12V				
Ratio	UNITS	31:1	61:1	86:1
Rated torque	kg-cm	9.3	18.3	25.8
Rated speed	rpm	84	43	30
Rated power (output)	W	10.3	10.3	10.3
Weight	kg	0.6	0.6	0.6

MOTOR DATA						
Rated volt (V)	Rated torque (kg-cm)	Rated speed (rpm)	Rated current (A)	No load speed (rpm)	No load current (A)	Rated input (W)
12	0.45	2600	1.6	3600	1.2	16
24	0.44	2800	0.8	4000	0.3	20

APPEARANCE SIZE

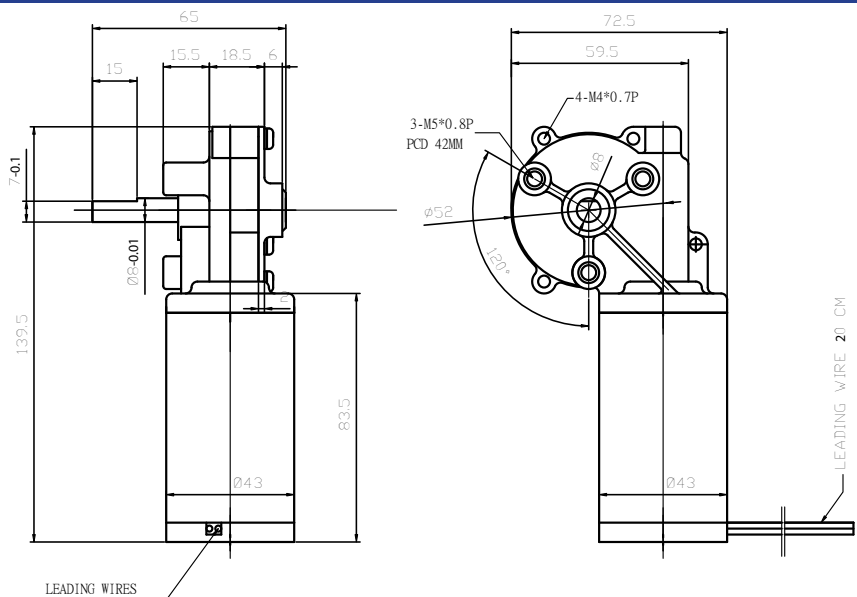

WRD6093 WORM GEAR DC MOTOR

Brush dc motors with robust design, plastic gears and closed motor body. Motor shafts are supported by ball bearings. Configurations may include gearbox, encoder and brake depending on motor model. Please check the part description for proper selections of combination. Customizations are welcome.

MODEL NO. DESIGNATIONS

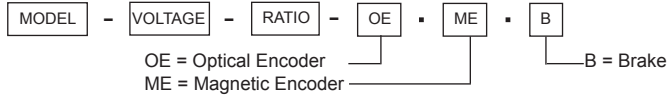

Example: WLDxxxx-12-60-OE

MOTOR FEATURES

- Robust design, closed motor body
- Ball bearings
- Gearbox combinations, plastic gears
- Encoder options
- Brake options
- Customizations are welcome



WORM GEAR DATA 12V		
Ratio	UNITS	
Ratio	UNITS	55:1
Rated torque	kg-cm	9.3
Rated speed	rpm	84
Rated power (output)	W	10.3
Weight	kg	1.1

MOTOR DATA						
Rated volt (V)	Rated torque (kg-cm)	Rated speed (rpm)	Rated current (A)	No load speed (rpm)	No load current (A)	Rated input (W)
12	1.2	2200	3	3300	1.3	38
24	1.2	3400	2.3	4200	0.65	41

APPEARANCE SIZE

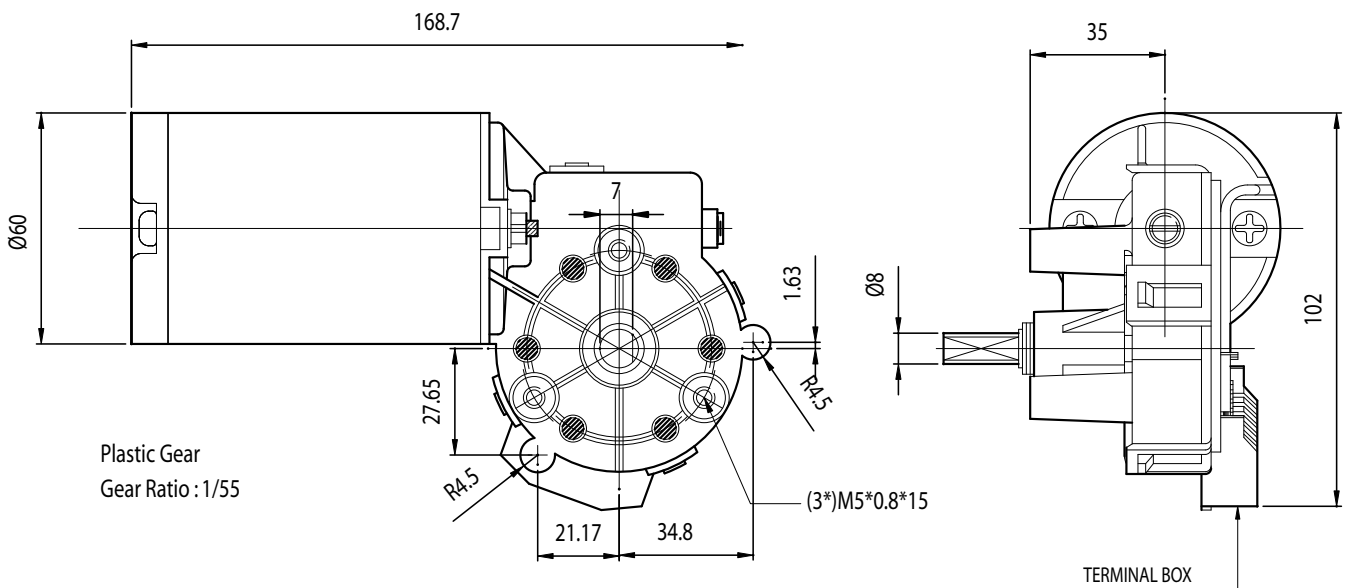

WRD63118 WORM GEAR DC MOTOR

Brush dc motors with robust design, metal gears and closed motor body. Motor shafts are supported by ball bearings. Configurations may include gearbox, encoder and brake depending on motor model. Please check the part description for proper selections of combination. Customizations are welcome.

MODEL NO. DESIGNATIONS

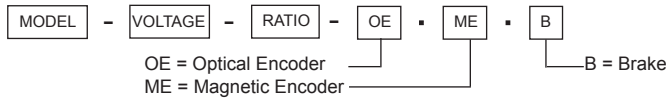

Example: WLDxxxx-12-60-OE

MOTOR FEATURES

- Robust design, closed motor body
- Ball bearings
- Gearbox combinations, metal gears
- Encoder options
- Brake options
- Customizations are welcome

TRANSMOTEC SWEDEN AB

WRD63118



ENCODER AND BRAKE VERSION AVAILABLE





SEE SEPARATE DATA SHEET

WORM GEAR DATA 12V				
Ratio	UNITS	10:1	15:1	30:1
Rated torque	kg-cm	11.7	16.2	28.1
Rated speed	rpm	240	160	80
Rated power (output)	W	22	22	22
Weight	kg	2.3	2.3	2.3

MOTOR DATA						
Rated volt (V)	Rated torque (kg-cm)	Rated speed (rpm)	Rated current (A)	No load speed (rpm)	No load current (A)	Rated input (W)
12	1.8	2450	5.1	3000	1.2	67
24	1.5	2750	2.2	3300	0.5	72

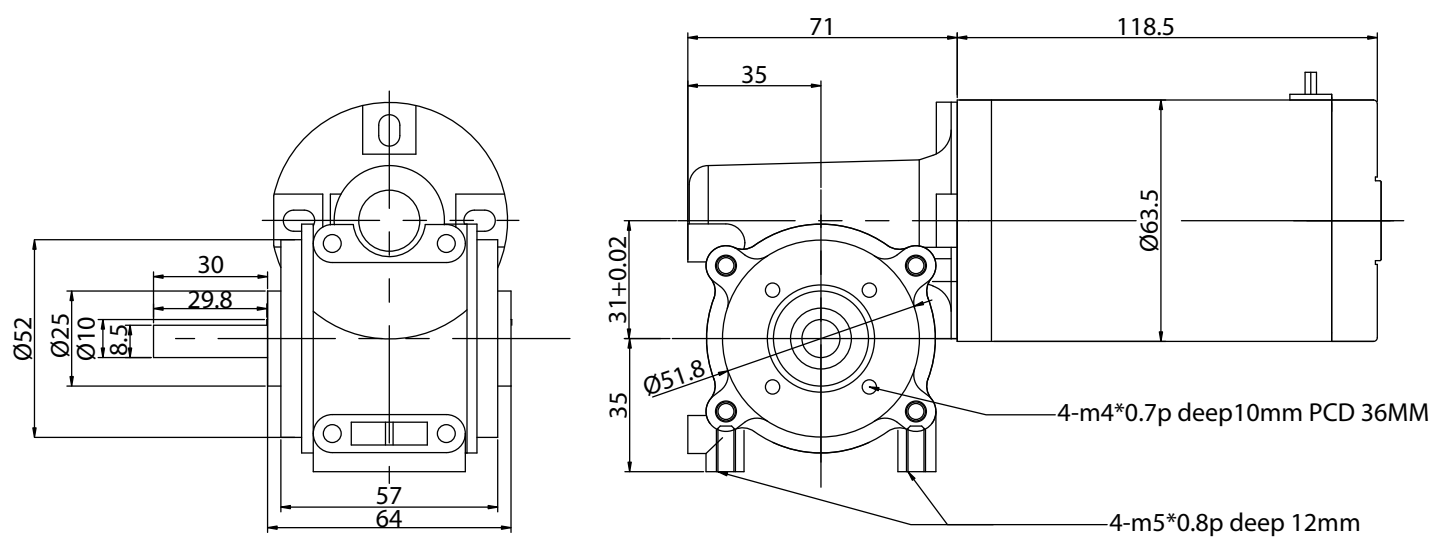
APPEARANCE SIZE



WRD65111 WORM GEAR DC MOTOR

Brush dc motors with robust design, metal gears and closed motor body. Motor shafts are supported by ball bearings. Configurations may include gearbox, encoder and brake depending on motor model. Please check the part description for proper selections of combination. Customizations are welcome.

MODEL NO. DESIGNATIONS

MODEL - VOLTAGE - RATIO

Example: WLDxxxx-12-60

MOTOR FEATURES

- Robust design, closed motor body
- Ball bearings
- Gearbox combinations, metal gears
- Encoder options
- Brake options
- Customizations are welcome

WORM GEAR DATA 12V

Ratio	UNITS	10:1	15:1	30:1
Rated torque	kg-cm	12.4	17.1	29.6
Rated speed	rpm	240	160	80
Rated power (output)	W	22	22	22
Weight	kg	2	2	2

MOTOR DATA

Rated volt (V)	Rated torque (kg-cm)	Rated speed (rpm)	Rated current (A)	No load speed (rpm)	No load current (A)	Rated input (W)
12	1.9	2400	5.5	3000	1.3	67
24	1.5	2700	2.3	3300	0.5	73

APPEARANCE SIZE

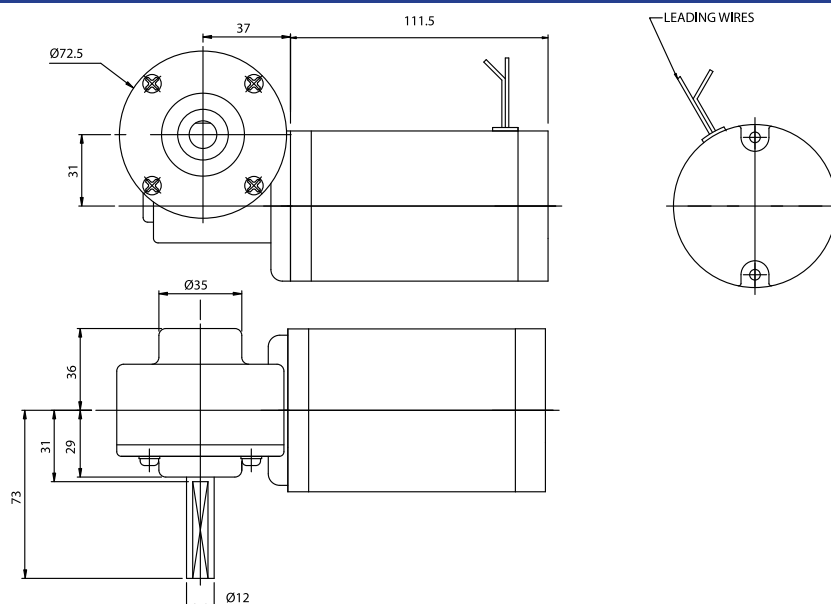

TRANSMOTEC SWEDEN AB

WRD65114 WORM GEAR DC MOTOR

Brush dc motors with robust design, metal gears and closed motor body. Motor shafts are supported by ball bearings. Configurations may include gearbox, encoder and brake depending on motor model. Please check the part description for proper selections of combination. Customizations are welcome.

MODEL NO. DESIGNATIONS

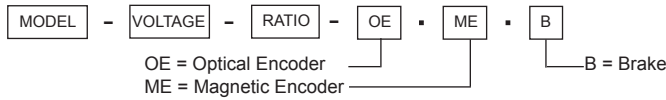

Example: WLDxxxx-12-60-OE

MOTOR FEATURES

- Robust design, closed motor body
- Ball bearings
- Gearbox combinations, metal gears
- Encoder options
- Brake options
- Customizations are welcome

WRD65114

ENCODER AND BRAKE VERSION AVAILABLE

SEE SEPARATE DATA SHEET

WORM GEAR DATA 12V				
Ratio	UNITS	10:1	15:1	30:1
Rated torque	kg-cm	12.4	17.1	29.6
Rated speed	rpm	240	160	80
Rated power (output)	W	22	22	22
Weight	kg	2.2	2.2	2.2

MOTOR DATA						
Rated volt (V)	Rated torque (kg-cm)	Rated speed (rpm)	Rated current (A)	No load speed (rpm)	No load current (A)	Rated input (W)
12	1.9	2400	5.5	3000	1.3	67
24	1.5	2700	2.3	3300	0.5	73

APPEARANCE SIZE

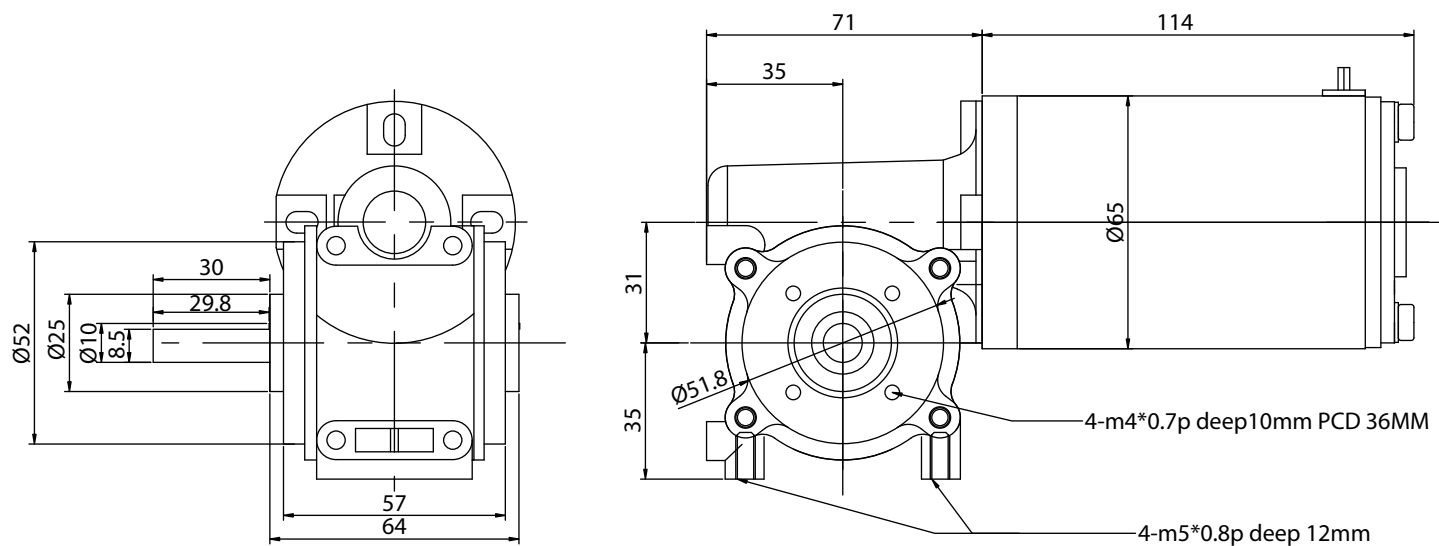

WLD8080 WORM GEAR DC MOTOR

Brush dc motors with robust design, plastic gears and closed motor body. Motor shafts are supported by ball bearings. Configurations may include gear-box, encoder and brake depending on motor model. Please check the part description for proper selections of combination. Customizations are welcome.



TRANSMOTEC SWEDEN AB

MODEL NO. DESIGNATIONS

MODEL - VOLTAGE - RATIO

Example: WLDxxxx-12-60

MOTOR FEATURES

- Robust design, closed motor body
- Ball bearings
- Gearbox combinations, plastic gears
- Encoder options
- Brake options
- Customizations are welcome

WORM GEAR DATA 12V

Ratio	UNITS	65:1
Rated torque	kg-cm	105
Rated speed	rpm	45
Rated power (output)	W	55
Weight	kg	2.4

MOTOR DATA

Rated volt (V)	Rated torque (kg-cm)	Rated speed (rpm)	Rated current (A)	No load speed (rpm)	No load current (A)	Rated input (W)
12	4.6	3230	11	3800	2	148
24	4.8	3250	6.1	3800	1.1	150

APPEARANCE SIZE

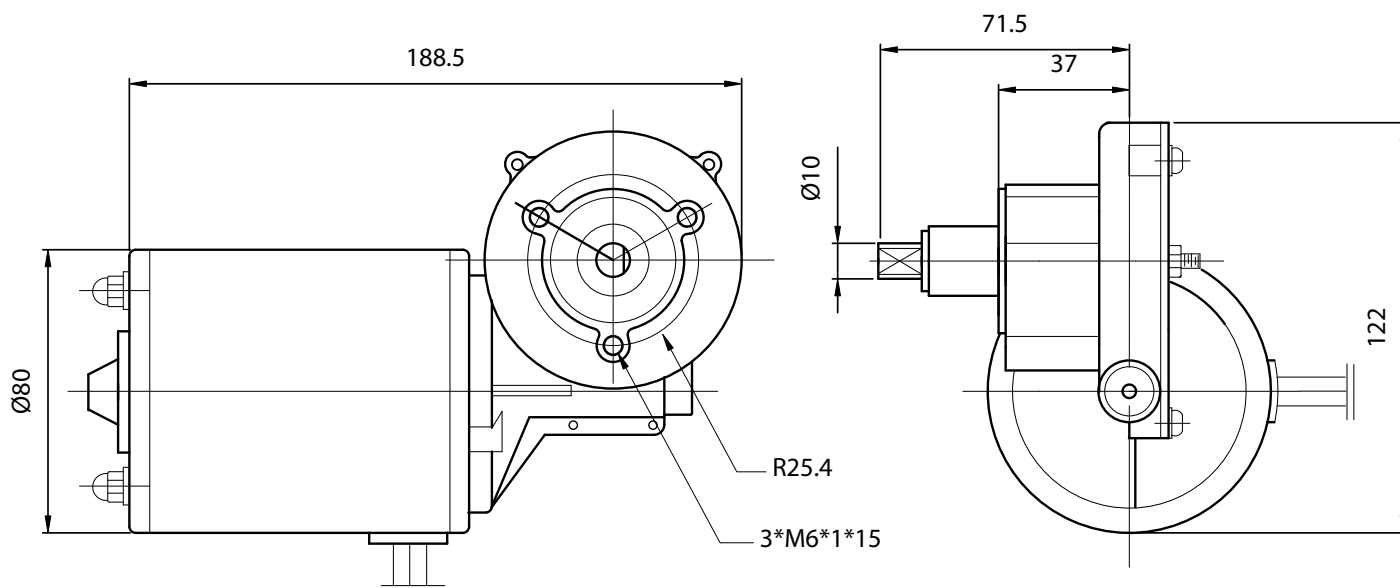

WRD8089 WORM GEAR DC MOTOR

Brush dc motors with robust design, plastic gears and closed motor body. Motor shafts are supported by ball bearings. Configurations may include gearbox, encoder and brake depending on motor model. Please check the part description for proper selections of combination. Customizations are welcome.



TRANSMOTEC SWEDEN AB

MODEL NO. DESIGNATIONS



Example: WLDxxxx-12-60

MOTOR FEATURES

- Robust design, closed motor body
- Ball bearings
- Gearbox combinations, plastic gears
- Encoder options
- Brake options
- Customizations are welcome

WORM GEAR DATA 12V		
Ratio	UNITS	50:1
Rated torque	kg-cm	105
Rated speed	rpm	47
Rated power (output)	W	55
Weight	kg	2.6

MOTOR DATA						
Rated volt (V)	Rated torque (kg-cm)	Rated speed (rpm)	Rated current (A)	No load speed (rpm)	No load current (A)	Rated input (W)
12	3.8	2450	11	2800	2	132
24	3.9	2800	6.2	3100	1.2	150

APPEARANCE SIZE

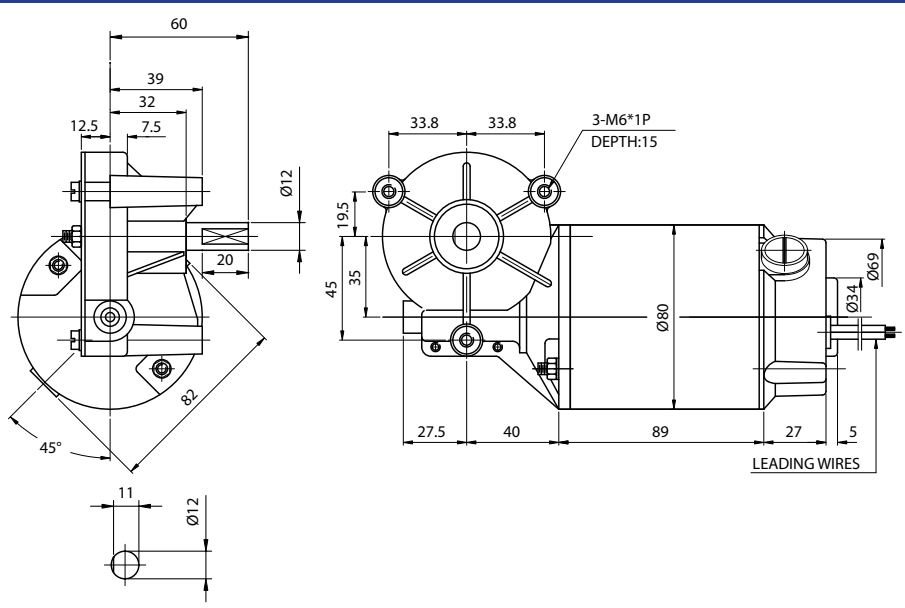

WRD80135 WORM GEAR DC MOTOR

Brush dc motors with robust design, metal gears and closed motor body. Motor shafts are supported by ball bearings. Configurations may include gearbox, encoder and brake depending on motor model. Please check the part description for proper selections of combination. Customizations are welcome.



MODEL NO. DESIGNATIONS



Example: WLDxxxx-12-60

MOTOR FEATURES

- Robust design, closed motor body
- Ball bearings
- Gearbox combinations, metal gears
- Encoder options
- Brake options
- Customizations are welcome

WORM GEAR DATA 12V

Ratio	UNITS	10:1	15:1	30:1
Rated torque	kg-cm	36	50.6	87.8
Rated speed	rpm	253	169	84
Rated power (output)	W	106	106	106
Weight	kg	2.8	2.8	2.8

MOTOR DATA

Rated volt (V)	Rated torque (kg-cm)	Rated speed (rpm)	Rated current (A)	No load speed (rpm)	No load current (A)	Rated input (W)
12	3.8	2450	11	2800	2	132
24	3.9	2800	6.2	3100	1.2	150

APPEARANCE SIZE

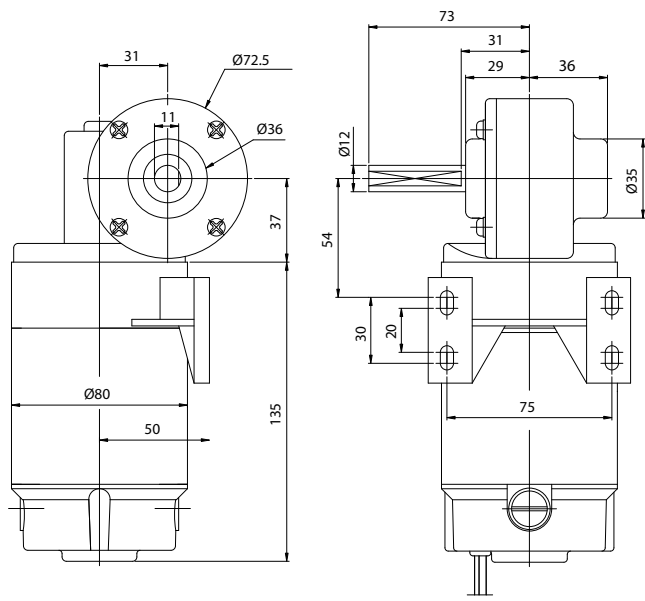

WLD80136 WORM GEAR DC MOTOR

Brush dc motors with robust design, metal gears and closed motor body. Motor shafts are supported by ball bearings. Configurations may include gearbox, encoder and brake depending on motor model. Please check the part description for proper selections of combination. Customizations are welcome.



TRANSMOTEC SWEDEN AB

MODEL NO. DESIGNATIONS



Example: WLDxxx-12-60

MOTOR FEATURES

- Robust design, closed motor body
- Ball bearings
- Gearbox combinations, metal gears
- Encoder options
- Brake options
- Customizations are welcome

WORM GEAR DATA 12V

Ratio	UNITS	20:1	25:1	30:1
Rated torque	kg-cm	67.5	84.4	94.5
Rated speed	rpm	127	101	84
Rated power (output)	W	106	106	106
Weight	kg	3.75	3.75	3.75

MOTOR DATA

Rated volt (V)	Rated torque (kg-cm)	Rated speed (rpm)	Rated current (A)	No load speed (rpm)	No load current (A)	Rated input (W)
12	3.8	2450	11	2800	2	132
24	3.9	2800	6.2	3100	1.2	150

APPEARANCE SIZE

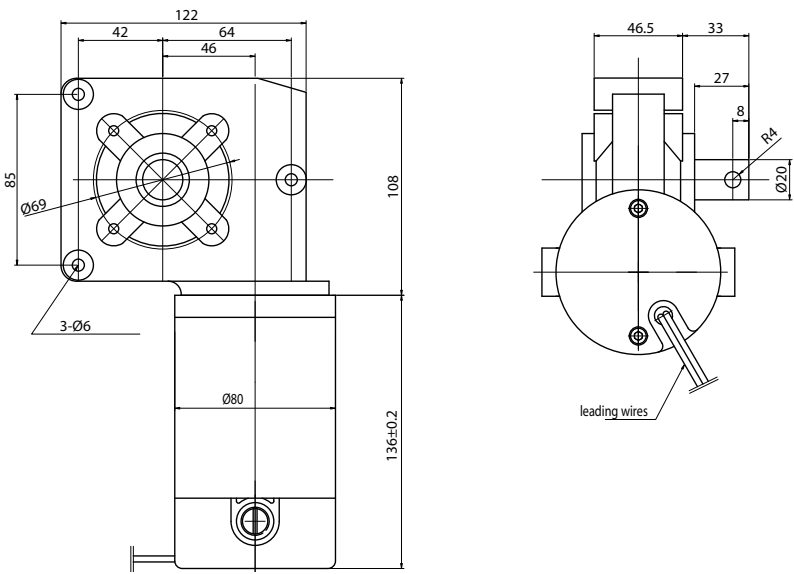

WHD80141 WORM GEAR DC MOTOR

Brush dc motors with robust design, metal gears and closed motor body. Motor shafts are supported by ball bearings. Configurations may include gearbox, encoder and brake depending on motor model. Please check the part description for proper selections of combination. Customizations are welcome.

MODEL NO. DESIGNATIONS

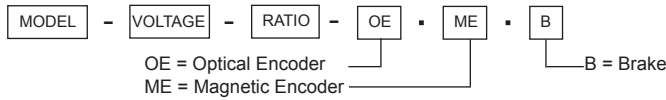

Example: WLDxxxx-12-60-OE

MOTOR FEATURES

- Robust design, closed motor body
- Ball bearings
- Gearbox combinations, metal gears
- Encoder options
- Brake options
- Customizations are welcome

TRANSMOTEC SWEDEN AB

WHD80141

ENCODER AND BRAKE VERSION AVAILABLE

SEE SEPARATE DATA SHEET

WORM GEAR DATA 12V								
Ratio	UNITS	10:1	15:1	20:1	25:1	30:1	40:1	50:1
Rated torque	kg-cm	40.5	59.4	73.8	86.6	91.8	108.0	123.8
Rated speed	rpm	253	169	127	101	84	63	51
Rated power (output)	W	106	106	106	106	106	106	106
Weight	kg	4	4	4	4	4	4	4

MOTOR DATA						
Rated volt (V)	Rated torque (kg-cm)	Rated speed (rpm)	Rated current (A)	No load speed (rpm)	No load current (A)	Rated input (W)
12	3.8	2450	11	2800	2	132
24	3.9	2800	6.2	3100	1.2	150

APPEARANCE SIZE

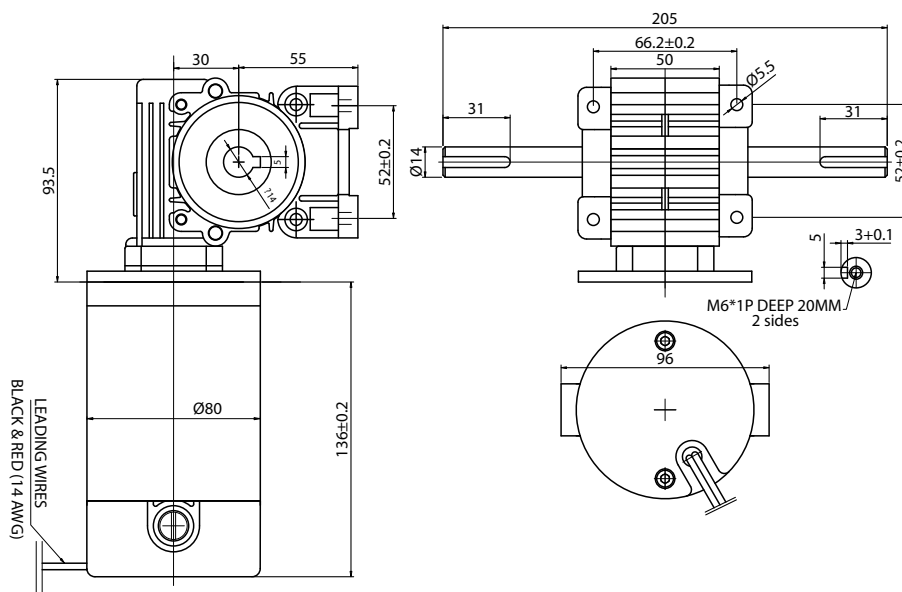

WHD80155 WORM GEAR DC MOTOR

Brush dc motors with robust design, metal gears and closed motor body. Motor shafts are supported by ball bearings. Configurations may include gearbox, encoder and brake depending on motor model. Please check the part description for proper selections of combination. Customizations are welcome.

MODEL NO. DESIGNATIONS

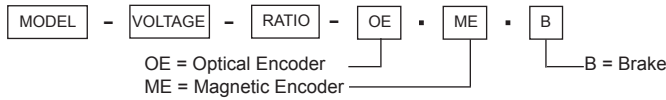

Example: WLDxxxx-12-60-OE

MOTOR FEATURES

- Robust design, closed motor body
- Ball bearings
- Gearbox combinations, metal gears
- Encoder options
- Brake options
- Customizations are welcome

TRANSMOTEC SWEDEN AB

WHD80155



ENCODER AND BRAKE VERSION AVAILABLE



SEE SEPARATE DATA SHEET

WORM GEAR DATA 24V								
Ratio	UNITS	10:1	15:1	20:1	25:1	30:1	40:1	50:1
Rated torque	kg-cm	48.6	71.3	88.6	104.0	110.2	129.6	148.5
Rated speed	rpm	262	175	131	105	87	66	52
Rated power (output)	W	138	138	138	138	138	138	138
Weight	kg	4	4	4	4	4	4	4

MOTOR DATA						
Rated volt (V)	Rated torque (kg-cm)	Rated speed (rpm)	Rated current (A)	No load speed (rpm)	No load current (A)	Rated input (W)
12	5.4	2620	7.5	3000	2.5	179
24	5.1	2600	13.8	3000	1.3	178

APPEARANCE SIZE

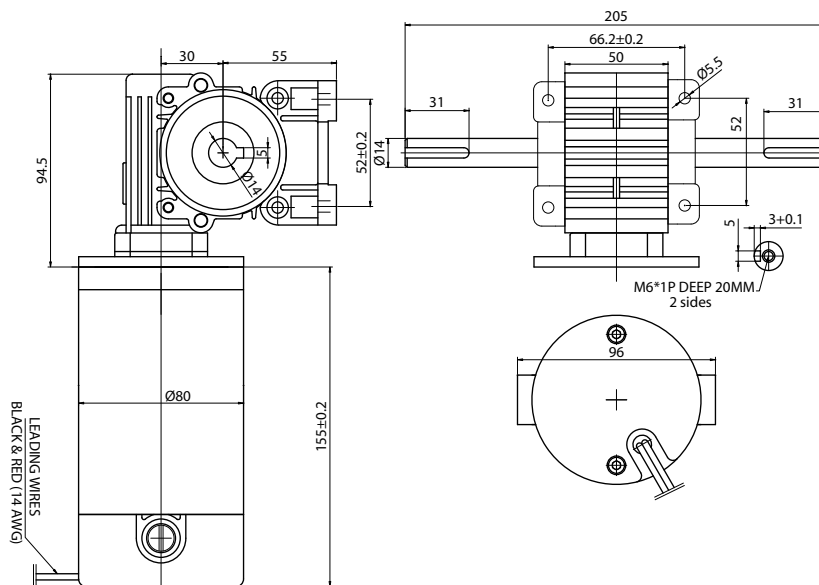

WHD80175 WORM GEAR DC MOTOR

Brush dc motors with robust design, metal gears and closed motor body. Motor shafts are supported by ball bearings. Configurations may include gearbox, encoder and brake depending on motor model. Please check the part description for proper selections of combination. Customizations are welcome.

MODEL NO. DESIGNATIONS

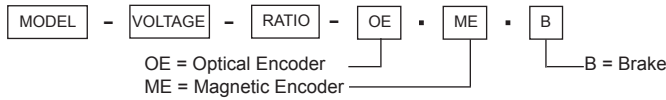

Example: WLDxxxx-12-60-OE

MOTOR FEATURES

- Robust design, closed motor body
- Ball bearings
- Gearbox combinations, metal gears
- Encoder options
- Brake options
- Customizations are welcome

TRANSMOTEC SWEDEN AB

WHD80175

ENCODER AND BRAKE VERSION AVAILABLE

SEE SEPARATE DATA SHEET

WORM GEAR DATA 24V								
Ratio	UNITS	10:1	15:1	20:1	25:1	30:1	40:1	50:1
Rated torque	kg-cm	63.0	92.4	114.8	134.8	142.8	168.0	192.5
Rated speed	rpm	316	211	158	126	105	79	63
Rated power (output)	W	216	216	216	216	216	216	216
Weight	kg	5	5	5	5	5	5	5

MOTOR DATA						
Rated volt (V)	Rated torque (kg-cm)	Rated speed (rpm)	Rated current (A)	No load speed (rpm)	No load current (A)	Rated input (W)
12	6.8	3200	23.2	3600	4.2	235
24	7	3220	12	3600	2	240

APPEARANCE SIZE

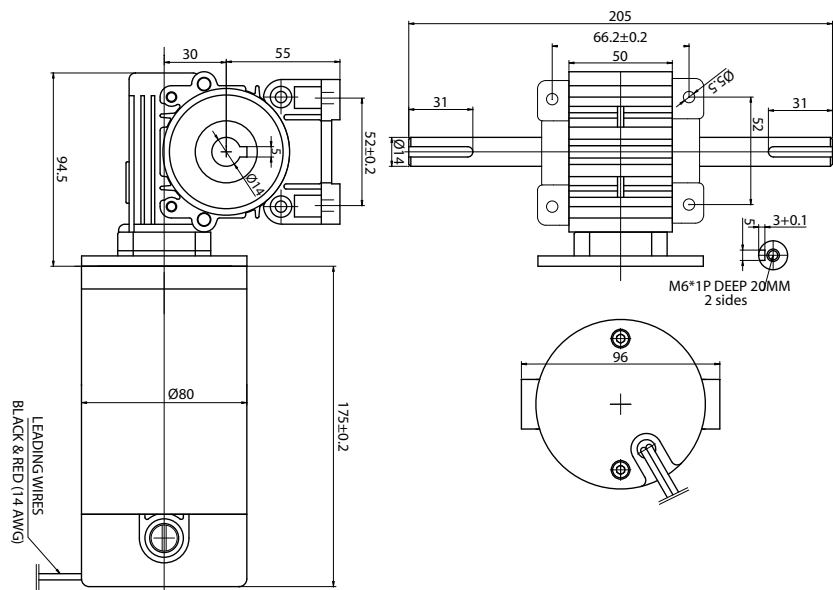

WLD89152 WORM GEAR DC MOTOR

Brush dc motors with robust design, metal gears and closed motor body. Motor shafts are supported by ball bearings. Configurations may include gearbox, encoder and brake depending on motor model. Please check the part description for proper selections of combination. Customizations are welcome.



TRANSMOTEC SWEDEN AB

MODEL NO. DESIGNATIONS



Example: WLDxxxx-12-60

MOTOR FEATURES

- Robust design, closed motor body
- Ball bearings
- Gearbox combinations, metal gears
- Encoder options
- Brake options
- Customizations are welcome

WORM GEAR DATA 12V

Ratio	UNITS	6:1	10:1	15:1	30:1
Rated torque	kg-cm	41.3	61.6	85.1	145.8
Rated speed	rpm	440	264	176	88
Rated power (output)	W	113	113	113	113
Weight	kg	3.4	3.4	3.4	3.4

MOTOR DATA

Rated volt (V)	Rated torque (kg-cm)	Rated speed (rpm)	Rated current (A)	No load speed (rpm)	No load current (A)	Rated input (W)
12	6.6	1680	13.8	2100	3.3	170
24	8.1	2640	12	3100	2.5	289

APPEARANCE SIZE

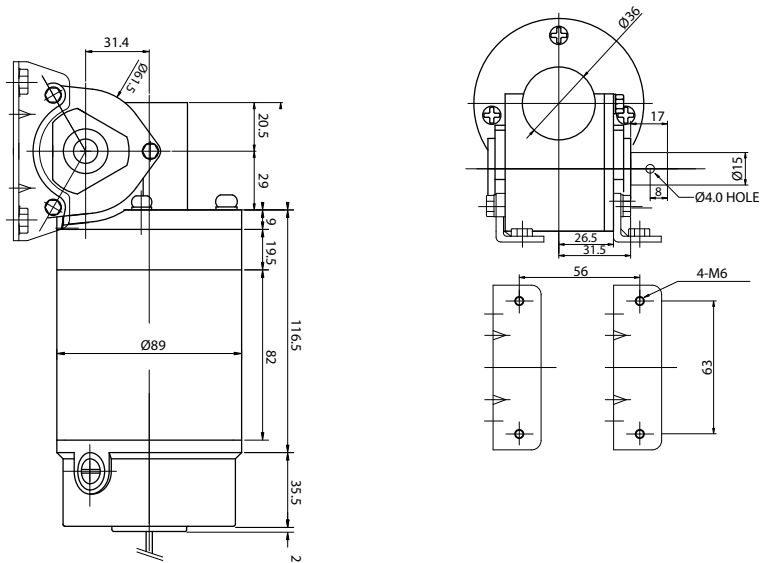

WHD123224 WORM GEAR DC MOTOR

Brush dc motors with robust design, metal gears and closed motor body. Motor shafts are supported by ball bearings. Configurations may include gear-box, encoder and brake depending on motor model. Please check the part description for proper selections of combination. Customizations are welcome.



TRANSMOTEC SWEDEN AB

MODEL NO. DESIGNATIONS



Example: WLDxxxx-12-60

MOTOR FEATURES

- Robust design, closed motor body
- Ball bearings
- Gearbox combinations, metal gears
- Encoder options
- Brake options
- Customizations are welcome

WORM GEAR DATA 24V

Ratio	UNITS	10:1	15:1	20:1	30:1	40:1
Rated torque	kg-cm	182.7	268.0	332.9	468.9	552.2
Rated speed	rpm	202	135	101	67	51
Rated power (output)	W	340	340	340	340	340
Weight	kg	10.5	10.5	10.5	10.5	10.5

MOTOR DATA

Rated volt (V)	Rated torque (kg-cm)	Rated speed (rpm)	Rated current (A)	No load speed (rpm)	No load current (A)	Rated input (W)
12	14.9	1500	26	1800	6	320
24	20.3	2020	23	2400	3.2	552

APPEARANCE SIZE

